

Vanguard® Filter



Table of Contents – Vanguard® Filters



Materials of Construction	3
Operating Characteristics	4
Cartridge Installation Instructions	5
Autoclave Instructions	6
Inline Steam Sterilization Procedure	7
Storage and Shelf Life	8
Part Number Matrix Description	
Cartridge	9
Small Flow Elements (SFE)	10
Capsule	11
UltraCap®	12
UltraCap® H.D.	13

Materials of Construction

The Vanguard® filter is manufactured using high quality components made from non-toxic and biologically inert raw materials. All components of the Vanguard® filter are FDA listed for food contact use in the Code of Federal Regulations (CFR), Title 21 as below:

Components

Media:	Polypropylene	CFR Title 21, 177.1520
Upstream support:	Polypropylene	CFR Title 21, 177.1520
Downstream support:	Polypropylene	CFR Title 21, 177.1520
Outer guard:	Polypropylene	CFR Title 21, 177.1520
Core:	Polypropylene	CFR Title 21, 177.1520
End caps:	Polypropylene	CFR Title 21, 177.1520
Adaptors:	Polypropylene	CFR Title 21, 177.1520
Capsule housing:	Polypropylene	CFR Title 21, 177.1520
O-rings:	Buna	CFR Title 21, 177.2600
	EPR	CFR Title 21, 177.2600
	Silicone	CFR Title 21, 177.2600
	Teflon® over Silicone	CFR Title 21, 177.1550
	Teflon® over Viton®	CFR Title 21, 177.1550
Sealing method:	Thermal bonding	

Dimensions (Nominal Sizes)

Cartridge	Diameter	Length
	2.75" (7 cm)	10" (25 cm)
		20" (50 cm)
		30" (75 cm)
		40" (100 cm)

SFE Cartridge	Diameter	Length
	2.25" (5,7 cm)	2.5" (6,4 cm)
		5" (12.7 cm)

Capsule	Diameter	Length
CL	2.75" (7,0 cm)	6.9" (17,5 cm)
CS	2.75" (7,0 cm)	4.5" (11,4 cm)
CF	2.25" (5,7 cm)	3.3" (8,3 cm)

UltraCap®	Diameter *	Cartridge Length (internal)	Capsule Dimension (overall)
T-style	3.25" (8 cm)	10" (25 cm)	12" (30,5 cm)
	<i>*inlet/outlet fittings extend beyond stated diameter</i>	20" (50 cm)	22" (56 cm)
		30" (75 cm)	31.5" (80 cm)
Inline	3.25" (8 cm)	10" (25 cm)	15" (38 cm)
		20" (50 cm)	24.5" (62 cm)
		30" (75 cm)	34" (86 cm)

UltraCap® H.D.	Diameter *	Cartridge Length (internal)	Capsule Dimension (overall)
T-style	3.5" (9 cm)	10" (25 cm)	13" (33 cm)
	<i>*inlet/outlet fittings extend beyond stated diameter</i>	20" (50 cm)	23" (58 cm)
		30" (75 cm)	32" (82 cm)
		40" (100 cm)	42" (106 cm)



Operating Characteristics

Cartridges and SFE (Small Flow Elements)

Maximum Operating Temperatures and Pressures

80 psid @ 32°F to 100°F

(Δp 5,5 bar @ 0°C to 38°C)

60 psid @ 150°F

(Δp 4,1 bar @ 66°C)

30 psid @ 180°F

(Δp 2,1 bar @ 82°C)

Capsules

Maximum Operating Pressure, Liquids

75 psig @ 32°F to 100°F

(5,2 bar @ 0°C to 38°C)

Maximum Operating Pressure, Gas

50 psig @ 32°F to 100°F

(3,4 bar @ 0°C to 38°C)

Maximum Operating Temperature Rating

160°F @ 35 psig

(71°C @ 2,4 bar)

UltraCap®

Maximum Operating Pressure & Temperature, Liquids

75 psig @ 32°F to 100°F

(5,2 bar @ 0°C to 38°C)

Maximum Operating Pressure & Temperature, Gas

50 psig @ 32°F to 100°F

(3,4 bar @ 0°C to 38°C)

45 psig @ 140°F

(3,1 bar @ 60°C)

30 psig @ 140°F

(2,1 bar @ 60°C)

UltraCap® H.D.

Maximum Operating Pressure & Temperature, Liquids

90 psig @ 32°F to 100°F

(6,2 bar @ 0°C to 38°C)

Maximum Operating Pressure & Temperature, Gas

60 psig @ 32°F to 100°F

(4,1 bar @ 0°C to 38°C)

55 psig @ 140°F

(3,8 bar @ 60°C)

35 psig @ 140°F

(2,4 bar @ 60°C)



Cartridge Installation Instructions

Meissner filters are available in a number of different adapter and O-ring configurations designed to fit modern filter housings. The filter should fit snugly in the housing. Improper installation can impair filtration efficiency.

1. Verify that the correct filter part number for the application has been chosen.
2. Keep the filter in its plastic bag to avoid contaminating the cartridge as long a possible. Cut open the bag at the O-ring end. While holding the bagged cartridge, lubricate the O-rings by dipping the O-rings into clean water or other suitable liquid compatible with the process fluid.
3. Line up the open end of the cartridge with the housing seat and install using a slight twisting motion while holding the bagged cartridge near the O-ring adapter. Verify that the O-rings are fully seated and not twisted. If the cartridge has locking tabs, rotate the tabs into place with a clockwise motion until engaged. Caution: always rotate cartridges while firmly grasping the O-ring end of the cartridge to prevent excessive torque damage to the filter.
4. Repeat with additional cartridges. Remove protective bags from the cartridges. If present, install cartridge retainer system (plate or spring). Reassemble housing.



Autoclave Instructions

Meissner filters may be autoclaved repeatedly without loss of integrity.

Capsule, UltraCap® and UltraCap® H.D. Filters

The following outlines the steps recommended in the autoclave sterilization of Meissner filter capsules. Gamma irradiated filters should not be autoclaved before use due to increased extractables and brittleness after both sterilization methods are employed.

- 1 Loosely cover the capsule inlet and outlet with autoclave wrap. All capsule vents are on the upstream side of the filter and should be loosened or removed to facilitate steam penetration.
- 2 The weight of clamps or fittings attached to the capsule must be supported to avoid damaging the adapters. Sanitary flanges may have clamps and gaskets loosely attached to the filter. If fittings must be attached to flanges, tri-clamps are preferable to bi-clamps and should be tightened after the assembly has cooled.
- 3 Autoclave the capsule at a minimum of 121°C for 60 minutes or 125°C for at least 45 minutes with the capsule in a horizontal position using a slow exhaust or liquid cycle. T-style UltraCap® capsules may be autoclaved horizontally or with the outlet oriented downward to facilitate the removal of condensate from the downstream side of the filter. As autoclave systems vary, sterilization cycles should be validated under actual system or autoclave loading conditions. Downstream attachments can significantly increase the time required to sterilize the filter core.
- 4 Allow the capsule to cool. Install filter into system aseptically.

Cartridge and SFE (Small Flow Elements)

The following outlines the steps required to autoclave a Meissner filter cartridge and housing assembly. A stainless steel reinforcement ring is required for filter configurations with 222 or 226 O-rings.

- 1 Install the filter into the housing. Loosely cover the inlet and outlet with autoclave wrap. Vent and drain valves should be fully open.
- 2 Autoclave the cartridge and housing assembly at a minimum of 121°C for 30 minutes with the filter outlets in an outlet down or horizontal position using a slow exhaust or liquid cycle. As autoclave systems vary, sterilization cycles should be validated under actual system or autoclave loading conditions. Assemblies attached to the outlet can increase the required sterilization times.
- 3 Allow the housing assembly to cool.
- 4 Install the sterile filter assembly into the system using aseptic techniques.

Different autoclave temperature and time combinations may be used to sterilize the filters but the combination should be validated to ensure that sterilization occurs under those conditions. Temperatures above 135°C are not recommended.



Inline Steam Sterilization Procedure

Steaming in place (SIP) is frequently used in critical applications where a sterile effluent is desired. To prevent damage to the filter cartridge's O-ring adapter, cartridges with 222 or 226 O-rings must be reinforced with a stainless steel ring. Meissner filter cartridges with reinforced O-ring adapters are capable of repeated sterilization cycles without loss of integrity. The steps required to steam sterilize a Meissner filter cartridge and system using saturated steam are outlined in the procedure, below.

The steam should be free of rust and other particulates. The housing should be clean before the cartridge is installed. If you are steam sterilizing a wetted cartridge, upstream and downstream gauges must be provided to verify that the differential pressure across the filter does not exceed 5 psi (0,3 bar). To assure sterilization, steam pressure in the assembly must not be allowed to fall below 15 psi (1 bar) or 121°C. Condensate should be drained from the system during sterilization. A typical piping schematic is outlined in Figure 1.

Caution: Capsules, UltraCap® and UltraCap® H.D. are not designed for inline steam sterilization!

Procedure (Figure 1)

1. Close all valves.
2. Open valve V₄.
3. If cartridge is wet, open V₅.
 - a. Slowly open V₂. This will connect both sides of the filter to steam pressure.
 - b. Crack open V₇ to vent trapped air.
 - c. Crack open V₆ allowing steam to flow through the system.
 - d. Slowly close V₅ but do not allow the differential pressure across the cartridge to exceed 5 psi (0,3 bar).
 - e. Leave drain V₈ cracked during sterilization to drain condensate.
4. If sterilizing a dry cartridge, slowly open V₂.
 - a. Crack open V₇ to vent trapped air.
 - b. Crack open V₆ to allow steam to flow through the system. Do not allow the differential pressure across the cartridge to exceed 5 psi (0,3 bar).
 - c. Leave drain V₈ cracked during sterilization to drain condensate.
5. Steam sterilize for 30 to 60 minutes at 15 to 20 psig (1,0 to 1,4 bar), or as long as experience dictates.
6. When sterilization is complete, close V₂.
7. Open V₃ and introduce sterile air or nitrogen regulated to the same pressure as the steam.
8. Close V₈ once steam and condensate flow stops.
9. Allow the system to cool to room temperature. Do not allow the differential pressure across the cartridge to exceed 5 psi (0,3 bar). Then close V₃, V₇ and V₆. Keep the system under pressure until ready for use.
10. Crack vent V₇ and allow the system pressure to equalize. The filtration process may now be started.

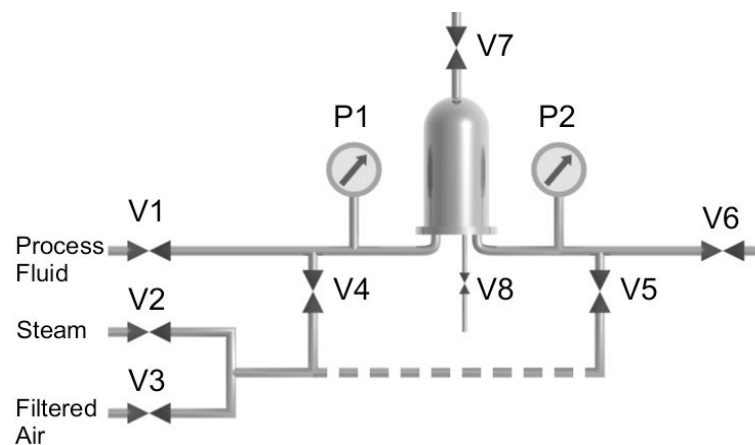

Figure 1



Storage and Shelf Life

Meissner Filtration Products, Inc. manufactures a complete line of filter products including cartridges, capsules and discs. Filters are suitably bagged and boxed for shipping and may be stored in the original packaging in a clean dry area between 0°C to 38°C (32°F to 100°F) for extended periods of time. The following gives the minimum shelf life expectancies for Vanguard® products.

Five Years

Vanguard® filters have an expected shelf life greater than five years in the cartridge, small flow, capsule and disc configurations. Filter age can be determined from the date on the original Certificate of Conformance.



Vanguard® - Media Description

MN = This pleated, depth type filter is constructed entirely of chemically resistant polypropylene. A Certificate of Conformance is available on a lot basis.

CARTRIDGES

MN	0.1	—	2	C6	R	S
Filter Media	Nominal Rating (µm)	—	Cartridge Length	End Cap Configuration	Reinforcement Ring Option	Seal Material (O-ring or Gasket)
MN	0.1, 0.2, 0.4, 1, 3, 5, 10, 30, 60, 99	—	1 = 10" 2 = 20" 3 = 30" 4 = 40"	GS = DOE; flat gaskets (9.75", 19.5", 29.25", 39" length filters) GL = DOE; flat gaskets (20", 30", 40" length filters) C1 = SOE; -222 nO-ring®, button cap end C2 = SOE; -222 O-rings, button cap end F1 = SOE; -222 nO-ring®, fin end F2 = SOE, -222 O-rings, fin end C5 = SOE; -226 nO-ring®, button cap end F5 = SOE; -226 nO-ring®, fin end C6 = SOE; -226 O-rings, button cap end F6 = SOE; -226 O-rings, fin end	(Blank) = Standard - no reinforcement ring R = Reinforcement ring required for autoclave/SIP applications	<p style="text-align: center;"><u>O-ring Seal</u></p> B = Buna E = EPR S = Silicone T = Teflon® over Silicone V = Viton® X = Teflon® over Viton®
						<p style="text-align: center;"><u>Gasket Seal</u></p> B = Buna E = EPR P = Polyethylene S = Silicone T = Teflon® V = Viton®

Small Flow Elements — SFE Configuration

L	MN	0.2	—	5	6	R	S
<input type="text"/>	<input type="text"/>	<input type="text"/>	—	<input type="text"/>	<input type="text"/>	<input type="text"/>	<input type="text"/>
Model	Filter Media	Nominal Rating (µm)	—	Filter Length/(Area) nominal	Adapter Selection	Reinforcement Ring Option	O-ring Material
L	MN	0.1, 0.2, 0.4, 1, 3, 5, 10, 30, 60, 99	—	2 = 2.5" (1000 cm ²) 5 = 5.0" (2000 cm ²)	P = Standard internal 116 O-ring 6 = -226 O-ring style locking adapter	(Blank) = Standard - no reinforcement ring R = Reinforcement ring - required for autoclave/SIP applications (available with -226 adapter only)	B = Buna E = EPR S = Silicone T = Teflon® over Silicone V = Viton® X = Teflon® over Viton®

Small Flow Elements — SKR Configuration

L	MN	0.2	—	5	SK
<input type="text"/>	<input type="text"/>	<input type="text"/>	—	<input type="text"/>	<input type="text"/>
Model	Filter Media	Nominal Rating (µm)	—	Filter Length/(Area) nominal	Adapter Selection
L	MN	0.1, 0.2, 0.4, 1, 3, 5, 10, 30, 60, 99	—	2 = 2.5" (1000 cm ²) 5 = 5.0" (2000 cm ²)	SK = Skirt-flange

CAPSULE — CS/CL

C	S	MN	0.2	—	02	2
<input type="text"/>	<input type="text"/>	<input type="text"/>	<input type="text"/>	—	<input type="text"/>	<input type="text"/>
Model	Filtration Area (nominal)	Filter Media	Nominal Rating (µm)	—	Inlet/Outlet	Upstream Vent(s)
C	S = 1.0 ft ² (1000 cm ²) L = 2.0 ft ² (2000 cm ²)	MN	0.1, 0.2, 0.4, 1, 3, 5, 10, 30, 60, 99	—	00 = 1" sanitary flange 02 = 1" sanitary flange inlet; 3/8" hose barb outlet 0C = 1" sanitary flange inlet; 1/2" hose barb outlet 22 = 3/8" hose barb 2B = 3/8" hose barb with filling bell CC = 1/2" hose barb 44 = 1/4" MNPT 55 = 3/8" FNPT 66 = 3/8" MNPT 77 = 3/4" sanitary flange	0 = No vent/drain port 1 = 1 Luer-Lok [®] port with cap, outlet side 2 = Standard - 2 Luer-Lok [®] ports with caps 4 = 2 sanitary valves with hose barb 5 = 1 sanitary valve with hose barb connection, outlet side

CAPSULE — CF

CF	MN	0.2	—	33	A	1
<input type="text"/>	<input type="text"/>	<input type="text"/>	—	<input type="text"/>	<input type="text"/>	<input type="text"/>
Model	Filter Media	Nominal Rating (µm)	—	Inlet/Outlet	Filtration Area (nominal)	Upstream Vents
CF	MN SC SP	0.1, 0.2, 0.4, 1, 3, 5, 10, 30, 60, 99 0.1 0.04, 0.1, 0.2, 0.4	—	33 = hose barb (1/4" - 3/8") 3B = hose barb (1/4" - 3/8") with filling bell 41 = 1/4" MNPT inlet; 1/4" hose barb outlet 44 = 1/4" MNPT 77 = 3/4" sanitary flange	A = 0.3 ft ² (300 cm ²) B = 0.5 ft ² (500 cm ²)	0 = No vent/drain port 1 = Standard - 1 Luer-Lok [®] port with cap, outlet side 2 = 2 Luer-Lok [®] ports with caps 4 = 2 sanitary valves with hose barb 5 = 1 sanitary valve with hose barb connection, outlet side

UltraCap® — T-Style

CU	MN	0.2	—	2	T	00	2
<input type="text"/>	<input type="text"/>	<input type="text"/>	—	<input type="text"/>	<input type="text"/>	<input type="text"/>	<input type="text"/>
Model	Filter Media	Nominal Rating (µm)	—	Cartridge Length	Body Style	Inlet/Outlet	Vent/Drain Ports
CU	MN	0.1, 0.2, 0.4, 1, 3, 5, 10, 30, 60, 99	—	1 = 10" 2 = 20" 3 = 30"	T = T-style	00 = 1" sanitary flange 02 = 1" sanitary flange inlet; 3/8" hose barb outlet 09 = 1" sanitary flange inlet; 9/16" hose barb outlet 0C = 1" sanitary flange inlet; 1/2" hose barb outlet 22 = 3/8" hose barb 77 = 3/4" sanitary flange 88 = 3/4" hose barb 99 = 9/16" hose barb AA = 1/2" Flaretek® BB = 3/4" Flaretek® CC = 1/2" hose barb	0 = No vent or drain 1 = No vent; 1/4" sanitary drain plug 2 = Sanitary vent; 1/4" sanitary drain plug 3 = Sanitary vent; 3/4" sanitary flange gauge port; 1/4" sanitary drain plug 4 = Sanitary vent; no drain 5 = Sanitary vent; 3/4" sanitary flange gauge port; no drain

UltraCap® — Inline

CU	MN	0.2	—	2	N	00	2
<input type="text"/>	<input type="text"/>	<input type="text"/>	—	<input type="text"/>	<input type="text"/>	<input type="text"/>	<input type="text"/>
Model	Filter Grade	Nominal Rating (µm)	—	Cartridge Length	Body Style	Inlet/Outlet	Vent/Drain Ports
CU	MN	0.1, 0.2, 0.4, 1, 3, 5, 10, 30, 60, 99	—	1 = 10" 2 = 20" 3 = 30"	N = Inline	00 = 1" sanitary flange 02 = 1" sanitary flange inlet; 3/8" hose barb outlet 09 = 1" sanitary flange inlet; 9/16" hose barb outlet 0C = 1" sanitary flange inlet; 1/2" hose barb outlet 22 = 3/8" hose barb 77 = 3/4" sanitary flange 88 = 3/4" hose barb 99 = 9/16" hose barb AA = 1/2" Flaretek® BB = 3/4" Flaretek® CC = 1/2" hose barb	0 = No vent/drain valves 2 = 2 vents/drain valves 4 = 1 vent/drain valve at outlet



UltraCap® H.D. (Heavy Duty)

CR	MN	0.2	—	2	T	00	2
<input type="text"/>	<input type="text"/>	<input type="text"/>	—	<input type="text"/>	<input type="text"/>	<input type="text"/>	<input type="text"/>
Model	Filter Grade	Nominal Rating (µm)	—	Cartridge Length	Body Style	Inlet/Outlet	Vent/Drain Ports
CR	MN	0.1, 0.2, 0.4, 1, 3, 5, 10, 30, 60, 99	—	1 = 10" 2 = 20" 3 = 30" 4 = 40"	T = T-style	00 = 1" sanitary flange 02 = 1" sanitary flange inlet; 3/8" hose barb outlet 09 = 1" sanitary flange inlet; 9/16" hose barb outlet 0C = 1" sanitary flange inlet; 1/2" hose barb outlet 22 = 3/8" hose barb 77 = 3/4" sanitary flange 88 = 3/4" hose barb 99 = 9/16" hose barb AA = 1/2" Flaretek® BB = 3/4" Flaretek® CC = 1/2" hose barb	0 = No vent or drain 1 = No vent; 1/4" sanitary drain plug 2 = Sanitary vent; 1/4" sanitary drain plug 3 = Sanitary vent; 3/4" sanitary flange gauge port; 1/4" sanitary drain plug 4 = Sanitary vent; no drain 5 = Sanitary vent; 3/4" sanitary flange ga

Luer-Lok is a registered trademark of Becton, Dickinson and Company.

Viton and Teflon are registered trademarks of DuPont Dow Elastomers L.L.C. & the DuPont Company.

Vanguard, UltraCap and UltraCap H.D. are registered trademarks of Meissner Filtration Products, Inc.

© 2007 Meissner Filtration Products, Inc.