



## UltraCap® Single-Use Capsule Filter Assembly

The high capacity UltraCap® capsule filter from Meissner meets a wide range of critical application requirements for a single-use, high-flow, high-throughput filter system. Designed for final filtration and prefiltration in the pharmaceutical, biotechnology, microelectronics and food & beverage industries, the UltraCap® filter is available in T-style and inline versions with a wide range of hydrophilic and hydrophobic filter media.

Typical pharmaceutical applications include sterile filtration of serum, tissue culture media, microbiological growth media and other viscous biological liquids, and sterile tank venting.

Typical microelectronics manufacturing applications include filtration of metal and oxide CMP slurries, chemical rinse solutions, acids, bases, solvents, stripping solutions, DI water and storage tank vents.

### Features and Benefits

- T-style and inline versions
- Extremely low hold-up volume design
- Specify Meissner's membrane filters in a choice of PVDF, PES, PP or PTFE, as well as PP microfiber, borosilicate glass microfiber, and PP microfiber depth media
- Removal ratings from 0.04 µm to 99 µm for final filtration through prefiltration of liquids and gases
- 10", 20" and 30" lengths (25 cm, 50 cm and 75 cm) permit sizing to optimize flow rate and throughput
- Sanitary flange, hose barb and Flaretek® end fittings provide maximum versatility
- Encapsulated, integral filter and housing system make change-outs quick and convenient, while reducing operator contact with liquids
- Single-use filtration system saves cleaning and cleaning validation costs
- Available gamma-irradiated for aseptic applications
- Recessed vent/drain at base of T-style configuration prevents breakage in use



**Materials of Construction**

Capsule Housing: Polypropylene (PP)

Filtration Media:

*Hydrophilic Membranes*

SteriLUX® Polyvinylidene fluoride (PVDF)

STyLUX® Polyethersulfone (PES)

EverLUX® Polyethersulfone (PES)

*Hydrophobic Membranes*

Steridyne® Polyvinylidene fluoride (PVDF)

Chemdyne® Polypropylene (PP)

Ultradyne® PTFE

*Microfiber*

ALpHA® Polypropylene (PP)

Vanguard® Polypropylene (PP)

Protec® RF Borosilicate glass (GF)

Protec® RM Borosilicate glass (GF) + SteriLUX® PVDF membrane

DeltaMax® Polypropylene (PP) depth

DeltaDepth® Polypropylene (PP) depth

Support Components: Polypropylene (PP)

Sealing Method: Thermal Bonding

**Max. Operating Press. & Temp. - Liquids**

75 psig @ 32 °F to 100 °F (5,2 bar @ 0 °C to 38 °C)

45 psig @ 140 °F (3,1 bar @ 60 °C)

**Max. Operating Press. & Temp. - Gases**

50 psig @ 32 °F to 100 °F (3,4 bar @ 0 °C to 38 °C)

30 psig @ 140 °F (2,1 bar @ 60 °C)

**Connections**

Inlet/Outlet: Sanitary flange, hose barb or Flaretek®

Vent Port: Sanitary valve with hose barb

Drain Port: Sanitary valve with hose barb;  
Sanitary plug (T-style option only)

Gauge Port: 3/4" sanitary flange  
(T-style option only)

**Cartridge Length (nominal)**

10", 20" or 30" (25 cm, 50 cm or 75 cm)

**Sterilization**

The UltraCap® assembly must be autoclaved at a minimum of 121 °C for 60 minutes with the inlet/outlet down.

UltraCap® assemblies can be repeatedly autoclaved without loss of integrity.

UltraCap® assemblies must not be in-situ steam sterilized (SIP) as exposure to direct steam flow at 121 °C, 15 psig (1 bar) will exceed material design limits and can result in rupture of the plastic housing.

**Mounting**

The UltraCap® assembly can be mounted and supported on suitably braced, rigid, inline pipe connections. A wall mounting bracket and accessory stand are also available. Contact Meissner for details.



## Configuration Dimensions

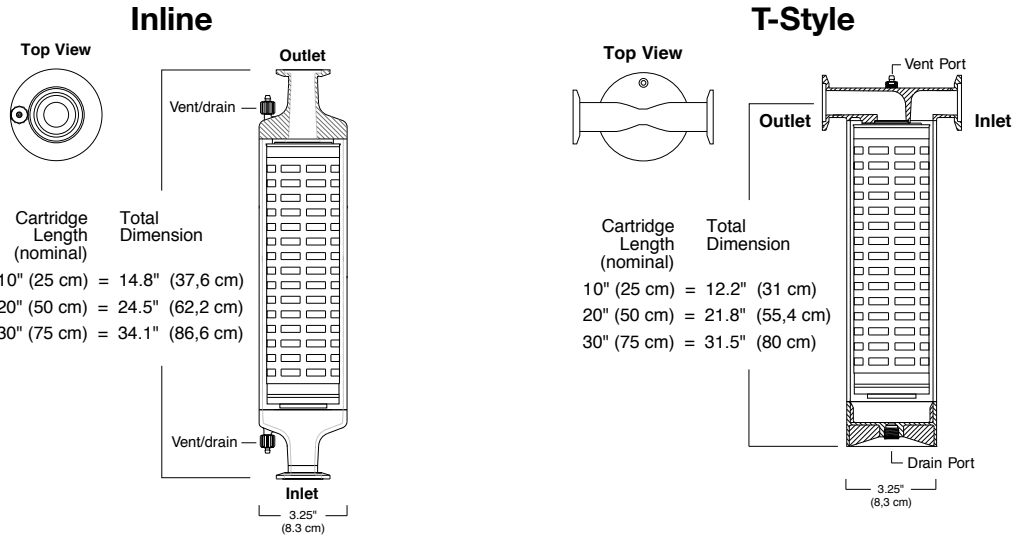

## Ordering Information

UltraCap® Model	Filter Media - Grade	Retention Rating (µm)	Cartridge Length	Body Style	Inlet/Outlet	Vent/Drain Ports	
CU	MF	5	2	T	00	2	
CU = Standard (non-sterile)	<b>Membrane Media</b>	<b>Grade</b>	<b>Retention Rating (µm)</b>	1 = 10"	T = T-style	00 = 1" sanitary flange	<b>T-Style</b>
	SteriLUX® PVDF	VMH <sup>2</sup> , VTH <sup>1</sup> , VLH <sup>3</sup>	0.1, 0.2, 0.4, 0.6	2 = 20"	N = Inline	77 = 3/4" sanitary flange	0 = No vent or drain
	EverLUX® PES	SMH <sup>2</sup> , SLH <sup>3</sup>	0.2, 0.4, 0.6	3 = 30"		02 = 1" sanitary flange inlet; 3/8" hose barb outlet	1 = No vent; 1/4" sanitary drain plug
GU = Gamma-irradiated	STyLUX® PES	STW <sup>1</sup> , SLW <sup>3</sup>	0.2			0C = 1" sanitary flange inlet; 1/2" hose barb outlet	2 = Sanitary vent; 1/4" sanitary drain plug
	SteriLUX® PES	SM <sup>2</sup> , SL <sup>3</sup>	0.04, 0.1, 0.2, 0.4, 0.6			09 = 1" sanitary flange inlet; 9/16" hose barb outlet	3 = Sanitary vent; 3/4" sanitary flange gauge port; 1/4" sanitary drain plug
	SteriLUX® PES	ST <sup>1</sup>	0.04, 0.1, 0.2, 0.4			08 = 1" sanitary flange inlet; 3/4" hose barb outlet	4 = Sanitary vent; no drain
	Steridyne® PVDF	VMV <sup>2</sup> , VTV <sup>1</sup>	0.2			22 = 3/8" hose barb	5 = Sanitary vent; 3/4" sanitary flange gauge port; no drain
	Gamma-irradiated model not available for media listed below:						6 = No vent or drain; 3/4" sanitary flange gauge port
	Chemdyne® PP	PM <sup>2</sup>	0.04, 0.1, 0.2			99 = 9/16" hose barb	8 = Sanitary vent; 3/4" sanitary flange gauge port
	Chemdyne® PP	PT <sup>1</sup>	0.2			88 = 3/4" hose barb	<b>Inline</b>
	Ultradyne® PTFE	TM	0.05, 0.1, 0.2, 0.4, 1.0, 5.0			AA = 1/2" Flaretek®	0 = No vent or drain
	Ultradyne® PTFE	TA <sup>2</sup> , TT <sup>1</sup>	0.2			BB = 3/4" Flaretek®	2 = Two sanitary vent/drain valves
	<b>Microfiber Media</b>	<b>Grade</b>	<b>Retention Rating (µm)</b>				4 = One sanitary vent or drain valve
	ALpHA® PP	MF	0.45, 0.6, 0.8, 1.2, 2.4, 5, 7, 10, 20, 30, 40, 70				
	Vanguard® PP	MN	0.1, 0.2, 0.4, 1, 3, 5, 10, 30, 60, 99 (nominal)				
	Protec® GF	RF*	0.5, 1				
	Protec® GF + PVDF	RM*	0.2, 0.3, 0.5				
	DeltaMax® PP depth	DM	0.5, 1, 3, 5, 10, 20, 40, 70				
	DeltaDepth® PP depth	DD	0.5, 1, 5, 10, 25, 50 (nominal)				

\*Protec® RF and RM are gamma-irradiatable

### Grade Descriptions

<sup>1</sup> T-grade (VTH, STW, ST, VTV, PT, TT)

This absolute, microbially rated filter meets full traceability requirements for the pharmaceutical industry. It is 100% integrity tested during manufacture. Each T-grade filter is shipped with a Certificate of Quality stating exact quality control criteria and test performance results. This is a validatable product to meet the stringent requirements of the pharmaceutical industry.

<sup>2</sup> M-grade (VMH, SMH, SM, VMV, PM, TA)

This absolute, microbially rated filter is 100% integrity tested during manufacture. It is suited for critical applications when regulatory documentation requirements are minimal.

<sup>3</sup> L-grade (VLH, SLH, SLW, SL)

This filter is not 100% integrity tested or flushed during manufacture. It is offered as an economical prefilter or final filter when sterility assurance is not required.

SteriLUX®, STyLUX®, EverLUX®, Steridyne®, Chemdyne®, Ultradyne®, ALpHA®, Vanguard®, Protec®, DeltaMax®, DeltaDepth®, UltraCap® and One-Touch® are registered trademarks of Meissner Filtration Products, Inc.

Flaretek is a registered trademark of Entegris Inc.

© 2012, 2007, 2005, 2004, 2001 Meissner Filtration Products, Inc. All rights reserved.